

# GaugeCalXP™ PRESSURE COMPARATOR

10000 PSI-700 bar

---

## Operator Instructions

## Introduction

Thank you for purchasing a **GaugeCalXP™** Pressure Calibrator from Crystal Engineering. The GaugeCalXP is a self contained, precision hydraulic pressure generator intended for the calibration of pressure gauges rated up to 700 bar or 10,000 PSI.

Two pressure ports are provided. Connect a reference grade gauge on one port (we recommend our XP2i Digital Pressure Gauge) and the gauge to be tested on the second port. Rotate the handle clockwise until the desired pressure is generated. Then, compare the displayed pressure values between the reference gauge and the gauge under test.

Pressure can be set very quickly and precisely. Gauges can be calibrated in less than ten minutes (5 to 10 test points, increasing and decreasing pressure) if you follow the method outlined in this manual. The comparator can be filled with your choice of water or oil.

The GaugeCalXP is much, much faster to use than a deadweight tester, and it's also faster than most automated pressure controllers, but it costs much less than either. It's so quick and easy to use, it's ideal to calibrate those low cost gauges that are often overlooked for ISO9000 compliance. Please spend a few minutes to read this manual, and learn how you can get the most benefit from your GaugeCalXP.

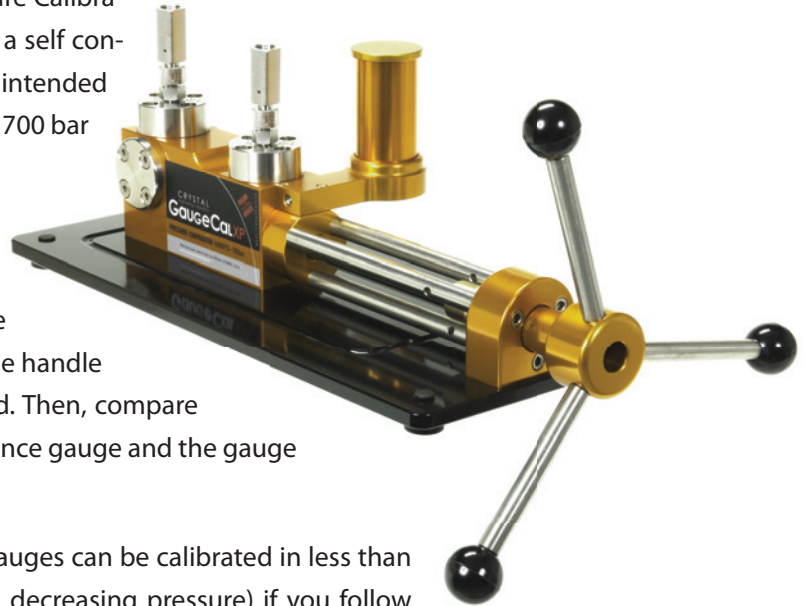

## Specifications

### Performance

#### Hydraulic

Maximum Pressure ..... 10,000 PSI / 700 BAR

Minimum Pressure.....5 PSI / 0.5 BAR

#### Pneumatic

Maximum Pressure ..... 400 inH2O / 995 mBAR

Sensitivity ..... 0.01 inH2O / 0.025 mBAR

Burst Pressure ..... >20,000 PSI / 1400 BAR

### Materials

Ram/Adapters ..... 316SS

Body ..... Aluminum

Seals ..... Buna N (Nitrile)

Test Media..... Water, Oil, or Air

### Dimensions

Width (of base) ..... 175mm (6.88 in)

Length (of base) ..... 429mm (16.88 in)

Length (overall).....495mm (19.50 in)

Weight ..... 6.4kg (14.2 lbs)

### Accessories (installed)

Adapters ..... (2) MPF-GC

### Accessories (included)

Adapters ..... (2) MPF-1/4FPT, (2) MPM-MPM

Wrenches ..... 2

### Shipping Information

Shipping Weight..... 8.6kg (19 lbs)

Dimensions ..... 559mm x 305mm x 229mm  
(22.0 in x 12.0 in x 9.0 in)

## Operation

For safe and reliable operation of your GaugeCalXP Pressure Comparator, please spend a few minutes reading the following instructions.

**1 Mount the comparator to your bench or table:** At higher pressures the force required to rotate the handle may cause the base of the comparator to lift. We recommend that the comparator be bolted to your bench or table. Refer to **Figure 1** for the hole pattern and suggested bolt sizes.

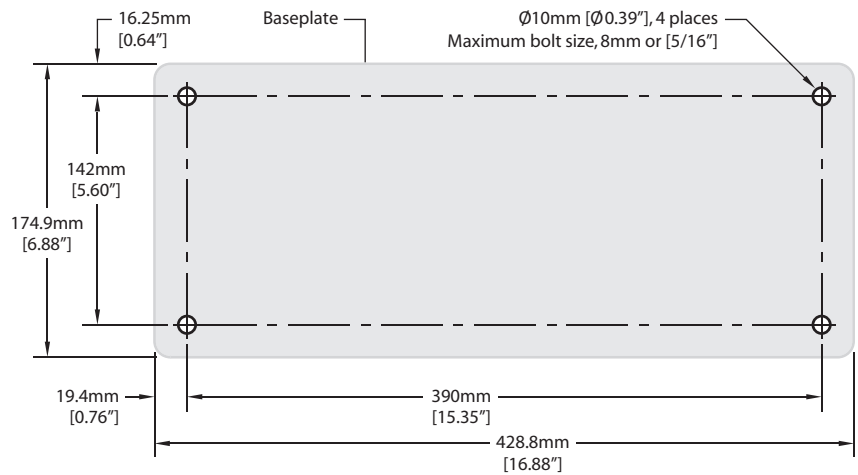

**Figure 1.** GaugeCalXP Pressure Comparator mounting hole pattern.

**2 Install the CPF-compatible fittings and any applicable adapters:**

The new Crystal Pressure Fittings (CPF) system greatly simplifies connecting your gauges, in addition to creating hand-tight, leak free connections up to 10 000 PSI/700 kPa/70 MPa working pressure. This system enables you to quickly connect and disconnect high pressure gauges using only your hands, and no sealing tape is required!

**Figure 2** shows the ways that the interior of CPF fittings seal; hand-tight and wrench-tight.

Your GaugeCalXP is fitted with a CPF base (7/16-20 MP) and will connect with the included MPM-MPM and the 1/4" fittings. Should you have a need for additional fittings, visit [www.crystalengineering.net](http://www.crystalengineering.net) or contact your Crystal Distributor.

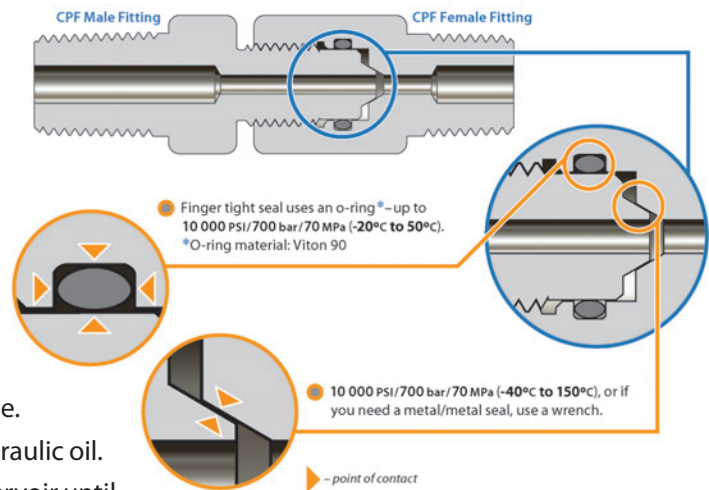

**Figure 2.** CPF fittings work to create a hand-tight 10 000 PSI / 700 bar / 70MPa seal.

**3 Fill the reservoir:** The reservoir holds the test fluid that fills the system each time you test a gauge. The test fluid can be either water or lightweight hydraulic oil. Wind the handle fully counter-clockwise, fill the reservoir until it is 25% full. Lift the back of the comparator six inches and tap on the side. The internal trapped air will be removed. The reservoir cap has an o-ring to allow the GaugeCalXP to be transported with the test fluids in place. Due to the sealing capabilities of the cap, it must be removed or ajar during testing to allow proper equalization of the system.

**4 Install the digital gauge:** Apply PTFE thread tape to the pressure gauge threads, then screw the gauge into the MPF-1/4FPT fitting. Be sure to use wrenches on both the fitting AND the gauge when tightening. Carefully turn the handle clockwise until the fluid is visible at the top of the MPM-MPM fitting. Connect the MPF-1/4FPT to the installed MPM-MPM, finger tight.

If you are using the quick test fittings (PN MPF-1/4QTF), just screw it onto the gauge, finger tight, then onto the installed MPM-MPM, also finger tight. Although wrench flats are provided on the quick test fitting, these are only intended to help remove the adapter.



**Figure 3.** The GaugeCal<sup>XP</sup> Pressure Comparator can be configured with an XP2i digital test gauge and a gauge to be tested, in either of the two ports. The above example also has the optional Fine Adjust option installed.

**CAUTION:** Never use a wrench to tighten a quick connect adapter.

**5 Install the gauge to be tested (Figure 3).** Repeat Step 4.

**6 Set up the digital pressure gauge:** Turn on the XP2i, and then select the pressure units required for the gauge to be tested—kg/cm<sup>2</sup>, bar, kPa, or PSI. (Refer to the documentation you received with your Crystal Engineering XP2i for detailed operating instructions.)

**7 Start the test:** We recommend that you exercise the gauges by applying the full scale pressure of the gauge being tested, one or more times. To apply pressure to the gauges, wind the handle in a clockwise direction. To decrease pressure to the gauges, wind the handle in a counter-clockwise direction. After decreasing the pressure to zero, re-check the fluid level in the reservoir, and rezero the XP2i, if necessary. You will notice that the application of pressure is non-linear, therefore pressure increases at a more rapid rate at higher pressures.

**Note:** If you cannot generate the desired pressure it is because one of two reasons: Either the system has too much air in it, or the volume being pressurized is too large. Repeat step 3 to bleed the system and start again. If this does not solve the problem, the volume is too large, and an auxiliary hydraulic pump is required.

**8 Compare pressure readings:** Wind the handle clockwise on the comparator so that the needle on the gauge being tested is centered on the first major graduation mark (or first calibration point). These major marks are usually placed at 10% or 20% increments of the full scale of gauge being tested. Hold the pressure for 15 seconds, then compare the pressure on the gauge to be tested to the pressure displayed on the XP2i digital gauge, and record the reading on the XP2i (**Figure 4**).

Normally, pressure will drop at first, as each ascending pressure point is reached. This is due to the residual, trapped gas, first heated by compression, then cooled, so that the compressed gas is at the same temperature as the ambient environment. An equal and opposite effect happens when reducing pressure—the pressure will rise as each new lower pressure is achieved. Waiting for these thermal effects to stabilize can add a lot of time to the calibration.

**9 Quick test method:** An alternative method eliminates the time required to wait for thermal pressure stability. Start by setting the XP2i into the Peak "Hi" mode and clearing any stored peak value. As above, increase pressure to the first major graduation on the gauge (or calibration point), but increase pressure slowly, so that you don't overshoot the mark (or point). The pressure recorded on the XP2i will be the pressure that was applied when the gauge was on the mark—even if actual pressure drops. Just record the reading from the XP2i and continue to the next test point or mark. If you are also checking the gauge for hysteresis, the procedure is the same, except that you start at full scale and set the XP2i to indicate the Peak "Lo", and then clear the peaks at full scale pressure. The XP2i will record the descending points in the same way.



**Figure 4.** Checking the accuracy of an analog pressure gauge against the display of the XP2i digital pressure gauge.

Eliminating the time required to wait for thermal equilibrium, significantly shortens the amount of time it takes to calibrate a gauge.

**Note:** Below the rear gauge flange base of the Pressure Comparator are ports for an optional Fine Adjust accessory. The Fine Adjust can be mounted on either side of the manifold block at the rear of the comparator. The Fine Adjust accessory (PN 3205) is helpful for fine pressure adjustment.

## Ordering Information

### Pressure Comparator

GaugeCalXP*	Pressure Comparator (up to 10,000 PSI)
GaugeCalXP-Skydrol†	Pressure Comparator, Skydrol compatible, includes Fine Adjust option and rebuild kit

\* Includes two CPF male-male fittings (P/N MPM-MPM) and two CPF 1/4" FNPT fittings (P/N MPF-1/4FPT).

† Contact Crystal for part numbers and pricing of any individual Skydrol compatible fittings.

### Options

3205	Fine Adjust kit option
3395**	Rolling Case for GaugeCalXP
FastCalXP	Gauge and Transmitter Calibration Software, USB Security Key, CD, USB-RS232 adapter, 30 series RS232 cable and manual
3327	USB Footswitch for FastCalXP
4138	Rebuild kit for GaugeCalXP
4158	Rebuild kit for GaugeCalXP-Skydrol

\*\* Includes two MPF-CAP fittings to prevent leaks while in transit, (2) hold-down straps, and fluid bottle.

### Fitting Kits

#### GaugeCalXP Conversion Fitting Kit

Convert previous versions of the GaugeCalXP to use the current CPF fitting system.

Includes:

**MPF-GC** (2), **MPF-1/4FPT** (2), **MPM-MPM** (2)

4012	Conversion kit - connects to nVision, XP2i, and M1
------	--

#### Quick Test NPT Kit - Finger-tight to working pressure up to 5KPSI / 350 bar

Quickly connect to various NPT fittings.

Includes:

**MPF-1/8QTF** (1), **MPF-1/4QTF** (1), **MPF-1/2QTF** (1)

4013	Quick Test NPT kit
------	--------------------



## Warranty

Crystal Engineering Corporation warrants the GaugeCalXP Pressure Comparator to be free from defects in material and workmanship under normal use and service for one (1) year from date of purchase to the original purchaser. It does not apply when the product has been misused, altered, or damaged by accident, or abnormal conditions of operation.

**For in (or out) of warranty service, we can be reached at:**

Phone..... (805) 595-5477	Phone (Toll Free)..... (800) 444-1850
Email..... <a href="mailto:service@crystalengineering.net">service@crystalengineering.net</a>	FAX ..... (805) 595-5466
Web..... <a href="http://www.crystalengineering.net">www.crystalengineering.net</a>	

If calling, have ready the model number, serial number, date of purchase, and reason for return. You will receive instructions for returning the device to Crystal Engineering.

Crystal Engineering will, at our option, repair or replace the defective device free of charge, and the device will be returned, transportation prepaid. However, if we determine the failure was caused by misuse, alteration, accident, or abnormal condition of operation, you will be billed for the repair.

**CRYSTAL ENGINEERING CORPORATION MAKES NO WARRANTY OTHER THAN THE LIMITED WARRANTY STATED ABOVE. ALL WARRANTIES, INCLUDING IMPLIED WARRANTIES OF MERCHANTABILITY OR FITNESS FOR ANY PARTICULAR PURPOSE, ARE LIMITED TO A PERIOD OF ONE (1) YEAR FROM THE DATE OF PURCHASE. CRYSTAL ENGINEERING SHALL NOT BE LIABLE FOR ANY SPECIAL, INCIDENTAL, OR CONSEQUENTIAL DAMAGES, WHETHER IN CONTRACT, TORT, OR OTHERWISE.**

**Note (USA only):** Some states do not allow limitations of implied warranties or the exclusion of incidental or consequential damages, so the above limitations or exclusions may not apply to you. This warranty gives you specific legal rights and you may have other rights which vary from state to state.

# CRYSTAL

engineering corporation

Copyright © 2009 Crystal Engineering Corporation  
708 Fiero Lane, Suite 9, San Luis Obispo, California 93401-8701

No part of this document may be reproduced or modified in any form or by any means, electronic or mechanical, without express written permission from Crystal Engineering Corporation.

Visit us on the web at [www.crystalengineering.net](http://www.crystalengineering.net)

